

REV	DATE	DESCRIPTION	DRAWN

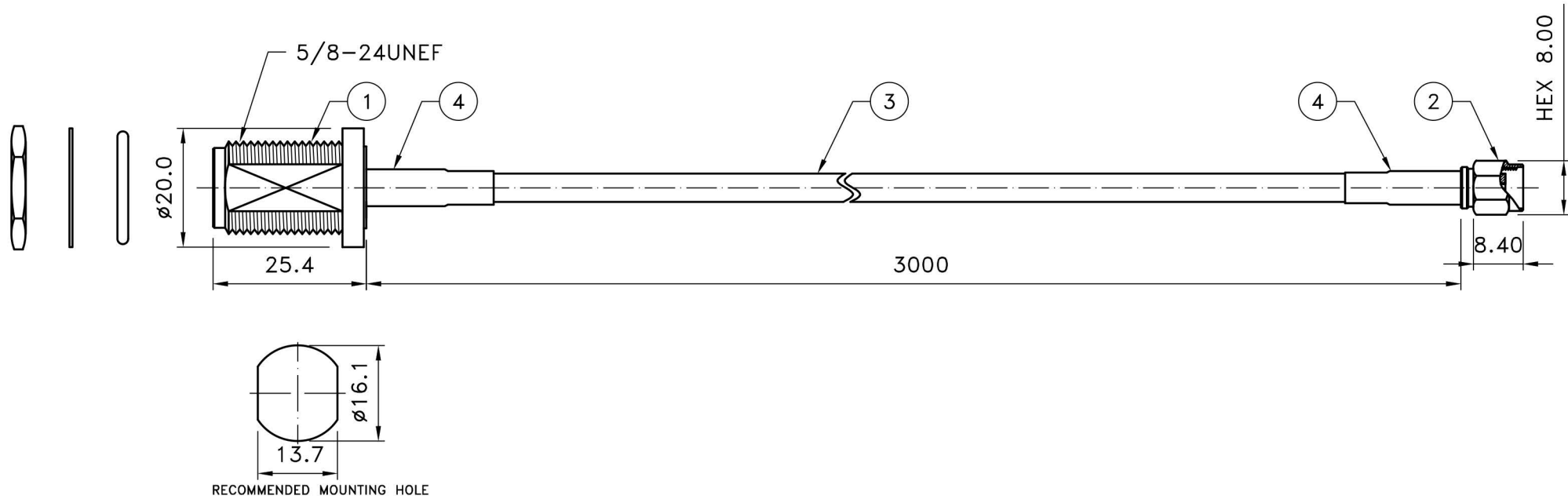

NOTE:

- 1.N FEMALE BULKHEAD CRIMP  
 CENTER PIN GOLD PLATING 3μ THICK OVER NICKEL STRIKE  
 BODY NICKEL PLATING 70μ THICK OVER NICKEL STRIKE  
 BRASS AND PTFE PER SGS  
 FINISH PLATING THICKNESS IN MICRO-INCHES  
 COPPER PARTS AUTOMATIC CNC MANUFACTURING
- 2.RP SMA MALE CRIMP  
 CENTER PIN GOLD PLATING 20μ THICK OVER NICKEL STRIKE  
 BODY GOLD PLATING 3μ THICK OVER NICKEL STRIKE  
 BRASS AND PTFE PER SGS  
 PTFE : TOMBO No.9002  
 FINISH PLATING THICKNESS IN MICRO-INCHES  
 COPPER PARTS AUTOMATIC CNC MANUFACTURING
- 3.LOW LOSS 200 COAXIAL CABLE/3D  
 ATTENUATION : 0.32dB/m@900MHZ 0.42dB/m@1800MHZ 0.61dB/m@3000MHZ  
 CONDUCTOR : BARE COPPER WIRE/Ø1.12mm  
 INSULATION : GAS-FPE/Ø2.95mm  
 TAPE : BONDED ALUMINUM FOIL  
 SHIELD : TINNED COPPER WARE/16\*4\*0.10mm/59% COVERAGE  
 JACKET : PVC/Ø4.95mm

Prohibit re-circulating



NO	DESCRIPTION	MATERIAL	FINISH	Q'ty
4	D0176 (SHRINK TUBE)	PE	BLACK	2
3	LLC200	ASSY	BLACK	1
2	SMA-1001-10-F2-RP-TGG	BRASS	GOLD	1
1	N-1112-24-F2-TGN	BRASS	NICKEL	1

NOTE	DIMENSION
1. STRIP ALL BURRS.	UNLESS OTHERWISE NOTED TOLERANCES 0.X=±0.2 0.XX=±0.1 CABLE LENGTH: L ≥ 10000 = +50 1000 ≤ L < 10000 = ±30 L < 1000 = ±8
2. ALL DIMENSIONS ARE AFTER PLATING.	
3. DIAMETERS ON COMMON CENTERS TO BE CONCENTRIC WITHIN 0.1 T.I.R	
4. CHAMFER 1ST & LAST THREADS 45°	
5. BREAK ALL CONNERS & EDGES CO.15 MAX.	

<b>WIFI-Link™</b> 台灣歲海尼可	
TITLE N female BKD to RP SMA male	
DRAWING NO. njb-rsmap-200-3.0	
APPROVED	DRAWN DATE 07/06/17
CHECKED	SCALE 1:1
DRAWN ALICE	UNIT mm